



White Paper

CELL SITE INSTALLATION AND COMMISSIONING- PIM OVER CPRI A NEW APPROACH TO PIM TEST.

Overview

This white paper focuses on the typical method of procedures (MOP) for cell site installation for greenfields and cell site upgrades (the majority of current installation works when carrier adds, technology upgrades (i.e. adding 5G) and the new spectrum is added into the network). This paper analyses and compares the traditional methods (two-tone RF testers) with Aceaxis' PIM and RF over CPRI tester (PIMForensics) and quantitatively differentiates the two methods based on the simplicity of use, functionality & features and time & cost.

Current test methods for PIM testing during cell site installation

Today there are two primary methods used to detect PIM:-

- **RF-based PIM testers** – These are portable test boxes that allow the Engineer to generate two 20W (or 40W) RF tones at a set RF frequency and to measure the effects of PIM.



A sample of typical RF PIM testers

- **PIM over CPRI** – A relatively new method using analysis of the digital bitstream (I/Q data) on the fibre interface between the BBU and RRH (Remote Radio Head) to measure the effects of PIM.



AceAxis IQ sensor & tap – PIMoCPRI Tester

Traditional 2-tone RF test method

Traditional RF based methods have been the mainstay test solution for the past 10 years and are valuable in helping to reduce the effects of PIM. For new 'greenfield' sites with no eNodeB/BTS installed RF PIM testers are the only way to currently test for PIM in the RF chain.

Most cell site installation these days involves adding RF band capabilities where existing network infrastructure is already present. RF PIM testers have a number of limitations which in modern multi band 4 and 5G networks are constraining the ability of the operator to quickly and effectively test and fix PIM. RF PIM testers are designed to test a single RF band, multiband testing can be conducted with RF PIM testers, however it is prohibitively expensive in test equipment and cannot be tested without a certified, qualified and experienced engineer. In addition, RF PIM test requires the cell site to be out of service for the duration of the test.

Often RF PIM test at the cell site is an interactive process where CW RF tones are generated by the PIM test box and a portable spectrum analyser and wand are used to physically walk round the site to look for PIM. This interactive process can take many hours, during which the cell site is off-air.

Additionally, these RF based test solutions typically require a complex set of instructions, several pieces of equipment (PIM Tester, PIM wand/probe & spectrum analyser) and tests, as illustrated in Figure 1 and in the flowchart (figure 2), on the next page.

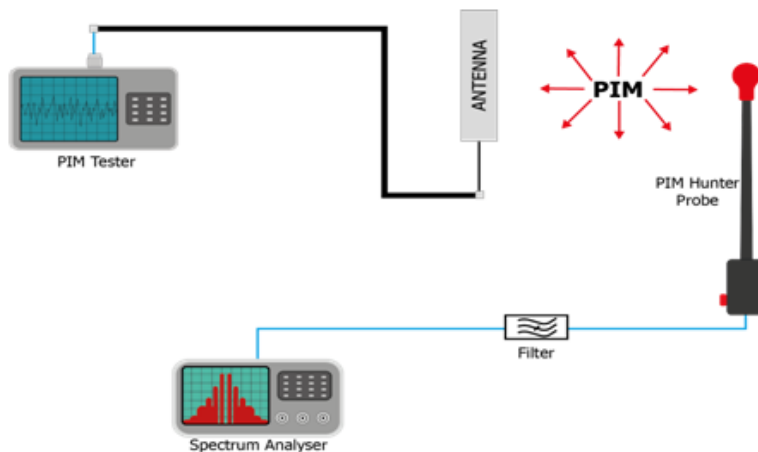

FIGURE 1 – RF-based PIM illustration

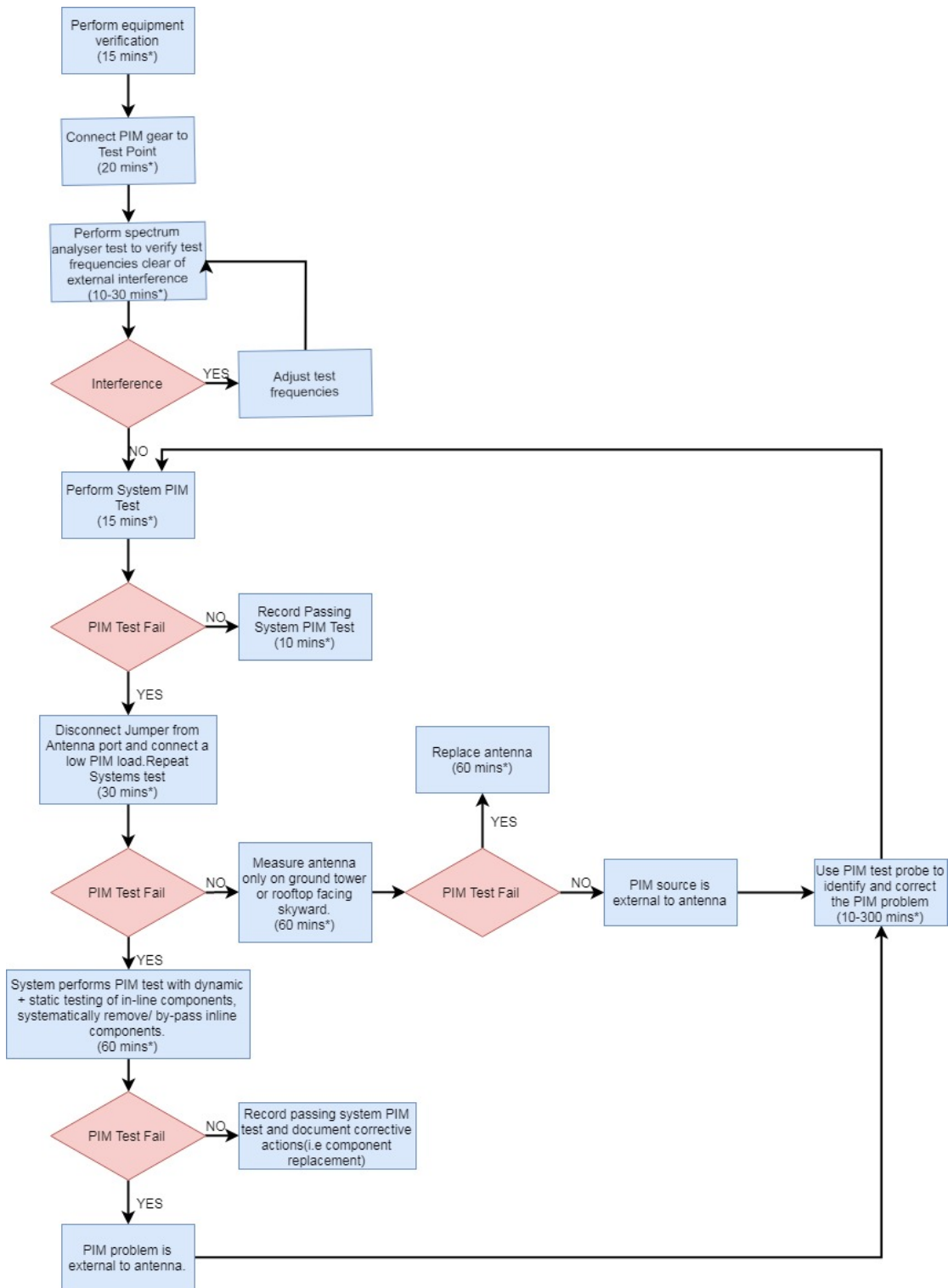

FIGURE 2 – RF-based typical PIM test flowchart

PIM over CPRI test methodology

PIM over CPRI is a non-intrusive PIM test method that requires a simple optical tap inserted between the Baseband Unit (BBU) and Remote Radio Head (RRH), refer to figure 3 below. An IQ sensor is connected to the tap and a patented algorithm is used that analyses the baseband IQ data streams and measures PIM in the presence of real-time traffic.

PIM over CPRI testing can be conducted at any cell site that has a BBU installed and site is carrying live traffic. The vast majority of current deployments are 'upgrades' where a BBU is present. A new 'greenfield' site with no BBU present would require a traditional RF test solution, but these are now a small percentage of 'new' cell sites.

This method brings the following advantages over RF-based PIM testers: -

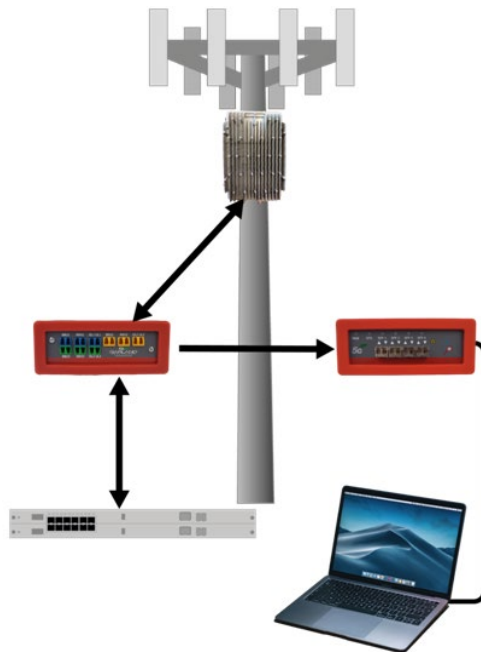
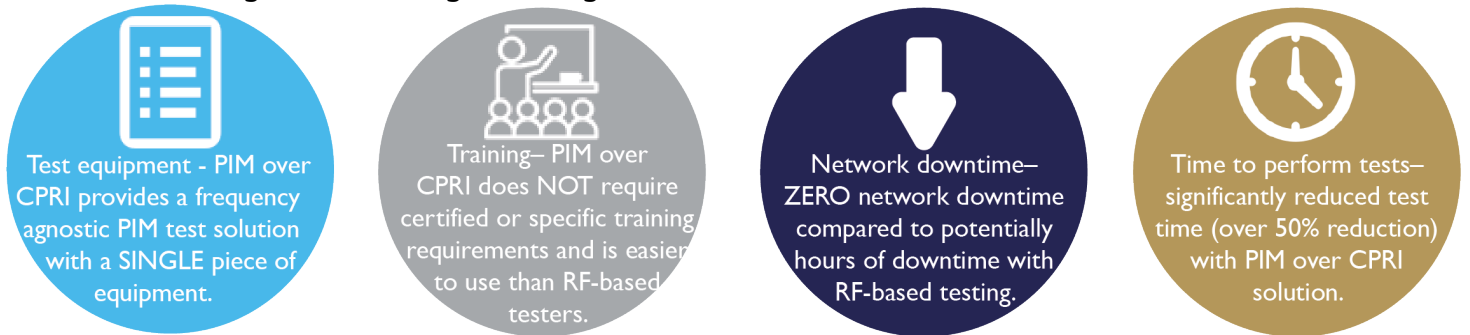

FIGURE 3 – PIM over CPRI

(PIMForensics) PIM test set up

Of important note, traditional RF-based testing usually requires significant diagnostic tests with BOTH dynamic (typically referred to as 'tap testing') and static testing. This test method is used to evaluate build quality and integrity and its primary purpose is to identify if any loose connectors are present. This is a

time-consuming test (many hours per cell site) and only provides a 'snapshot' of the cell site at that specific point in time with NO actual site traffic.

These tests can be totally eliminated with PIM over CPRI as long-term monitoring under real-time traffic conditions can be conducted, if there is a loose connector but there is zero PIM whilst monitoring then there is no requirement to take action. However, if PIM is detected, possibly during a period of heavy wind that vibrates the antenna and mount infrastructure and RF cable connectors creating PIM, this will be detected during the long term monitoring and further action can be taken.

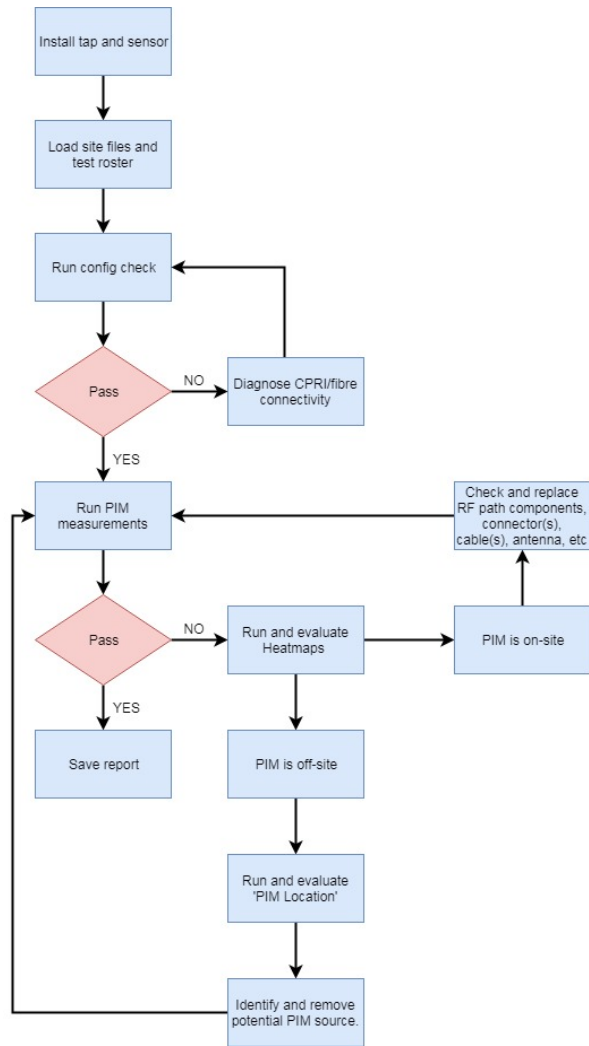

FIGURE 3 – PIM over CPRI (PIMForensics) PIM test set up

Advantages of PIM over CPRI testing

Here is a comparison of 'old' (RF-based) versus 'new' (CPRI based) PIM testing:-

Metric	Old	New	Comments
Equipment set-up, verification and calibration.	>1 hour	<30 mins	Significant time (and cost) saving with new method.
NO sector or cell outage.	x	✓	ZERO outage with new method (or less than 5 minutes if tap needs to be installed). Long-term (>30 minutes) required for old method. No restriction to testing during maintenance period only.
NO requirement to evaluate test frequencies (with spectrum analyser).	x	✓	New method requires no 'test' frequencies, uses actual licensed carriers at site.
No Broadcast of potentially ' unlicensed' CW signal.	x	✓	New method does not require test/unlicensed frequency bands.
Multi-frequency capability (all 4G & 5G bands).	x	✓	New method supports ALL 3GPP bands, old method requires dedicated test sets for specific frequency bands.
Cross-band PIM testing with single piece of equipment.	x	✓	Cost and time saving with ONE piece of test equipment for new method.
True, accurate PIM measurements under 'live' traffic conditions.	x	✓	New method evaluates PIM level against actual traffic levels allowing a very quick determination of its impact to service.
Long Term PIM monitoring with event log.	x	✓	New method can be left to collect data for hours or days, can be remotely monitored in real time.
Heatmaps (isolate PIM to internal/external antenna port(s))	x	✓	Only product to offer patented 'heatmap' evaluation of PIM location.
Distance to PIM/PIM location.	✓	✓	
Detailed report generation.	✓	✓	
No Certification required to use equipment	x	✓	Savings in training and upfront product use costs.
Ease of use (1=easy, 5=expert)	4	2	

Summary

PIM over CPRI represents the next step in PIM test and is designed to support modern 4 and 5G networks. Working from the key principle that the site should have minimum down time and complementing this with more accurate and capable measurement techniques which also use tools to reduce the knowledge required to make complex multi band PIM measurements PIM Forensics represents an important addition to the world of PIM test and an addition that is designed to lower the cost of PIM test.